



Description

Pumping equipment consisting of volumetric type electro pumps of ceramic pistons of a 40 L/min flow, pressure of 140 bar and a three-phase electric engine of 220/380V and 15 C.V (11.04 kw) plus a jockey pump with a flow of 2.6 l/min regulated to a pressure between 30 and 40 bar, with a three-phase electric motor of 380 V and 3 C.V (2,2 kw). The electric control cabinet that regulates the functioning of the equipment is designed according to the UNE 23500 norm and allows the emission of remote alarms. The equipment consists of a pump controlled by a frequency variator and the other through a soft starter. It is delivered assembled over a universal workbench, regulated according to the work pressure, depending on the project and has been verified its correct functioning.

Consumption Data Information

Reference	Flow volume(l/min)	C.V. total of the motors	KW total of the motors	Length (mm)	Width (mm)	Height H (mm)
AN/GAH1-12	12	5	3,68	1100	900	1750
AN/GAH1-25	25	14,5	10,67	1100	900	1750
AN/GAH2-25	50	27	19,87	1500	900	1750
AN/GAH1-40	40	20	15	1100	900	1750
AN/GAH2-40	80	35	26	1500	900	1750
AN/GAH3-40	120	50	38	1950	1400	1860

Dimensiones

Dimensions may vary by according to amount of directional valves and compressor of installation.

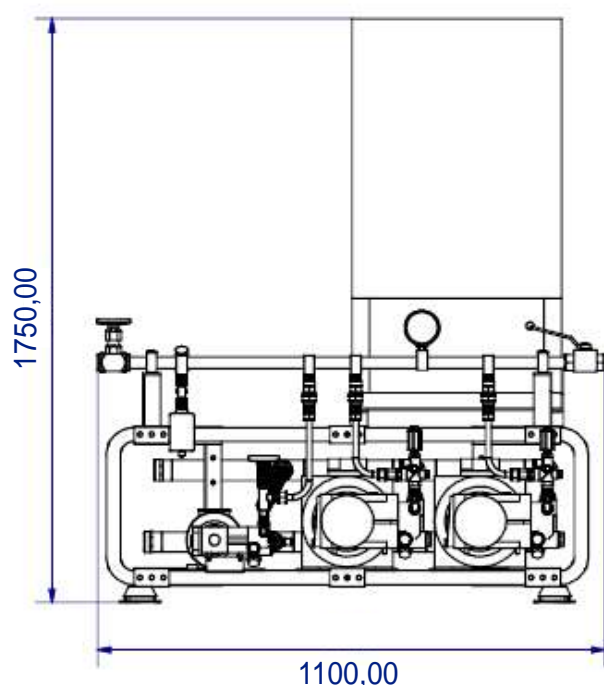

Equipment

The pumping equipment is delivered with:

- Flexible high-pressure hose for the pumping, of 1" and 600 mm in length. Swivel female connection, thread size BSP 1".
- Flexible high-pressure hose for the tests, of 1" and 600 mm in length. Swivel female connection, thread size BSP 1".
- Hose of aspiration at low pressure for the aspiration of 2" and 600 mm in length. Male connection thread size BSP 2".
- Return hose of low pressure, of 2" and 600 mm in length. Male thread connection BSP 2".

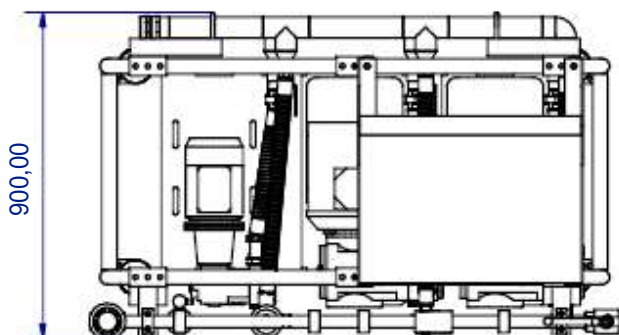

Pumping equipment for wet tubes for up to 3 main pumps

Elements

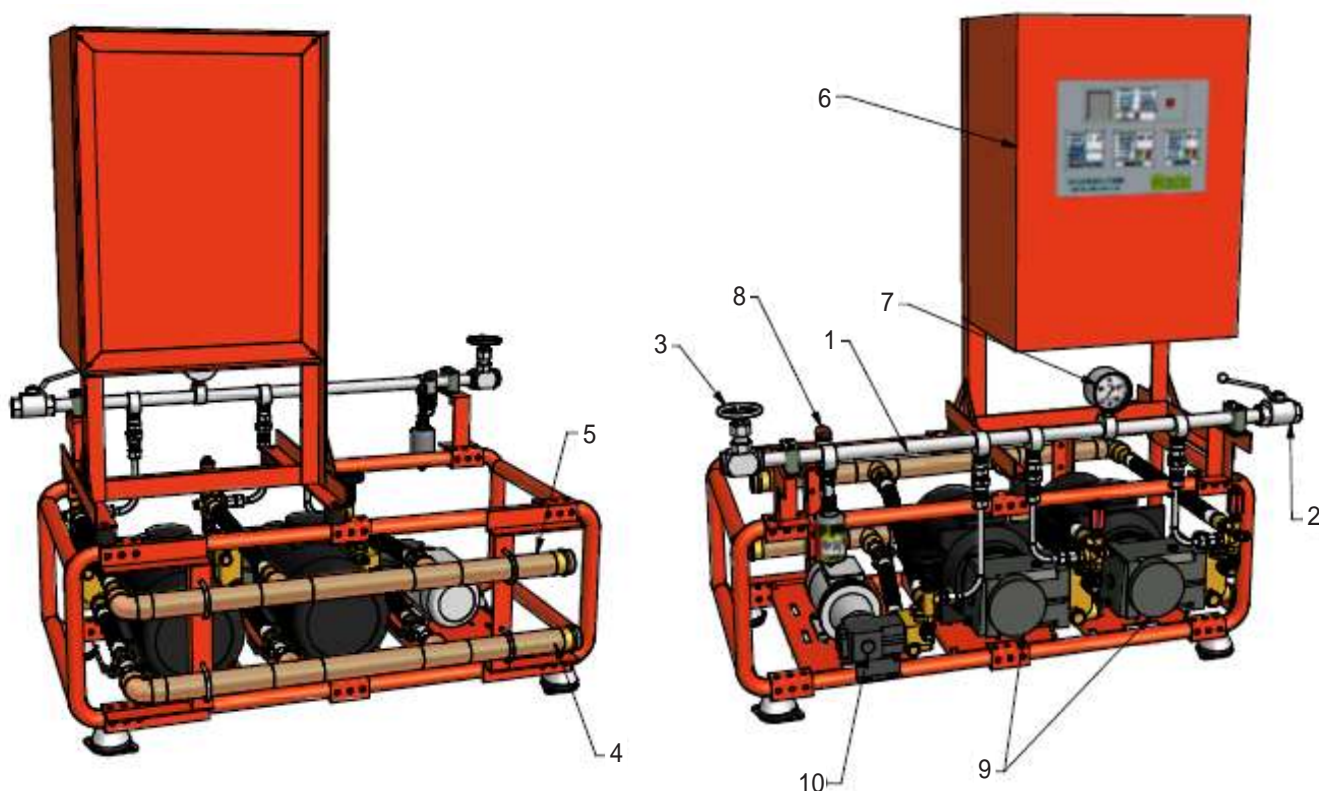

Elements	
Nº Id	Description
1	1" Upstream manifold
2	1" Return valve
3	Test valve female 1"
4	Aspiration feeding pump 2"
5	Return Manifold 2"
6	Electrical Control Panel
7	250 Manometer
8	Pressure regulator
9	Pump 40 Lxmins, 1500 rpm 11 KW.
10	Jockey pump for wet water mist system.